

TPA6205A1DRB Audio Power Amplifier EVM

Contents

1	Introduction	1
2	Operation	4
3	Related Documentation From Texas Instruments	11

List of Figures

1	The TI TPA6205A1DRB Audio Amplifier Evaluation Module	3
2	Quick Start Platform Map	5
3	Quick Start Module Map	7
4	TPA6205A1DRB EVM Connected for Stereo BTL Output	8
5	TPA6205A1DRB EVM Schematic Diagram	9
6	TPA6205A1DRB EVM Top Layer	10
7	TPA6205A1DRB EVM Bottom Layer	11

List of Tables

1	Typical TI Plug-N-Play Platform Jumper and Switch Settings for the TPA6205A1DRB EVM	4
2	Platform Jumper and Switch Settings for the TPA6205A1DRB EVM	6
3	TPA6205A1DRB EVM Parts List	9

1 Introduction

This chapter provides an overview of the Texas Instruments (TI) TPA6205A1DRB audio amplifier evaluation module. It includes a list of EVM features, a brief illustrated description of the module, and a list of EVM specifications.

1.1 Feature Highlights

The TI TPA6205A1DRB audio amplifier evaluation module and the TI plug-n-play audio amplifier evaluation platform include the following features:

- TPA6205A1DRB Low-Voltage Audio Power Amplifier Evaluation Module
 - 3 mm × 3mm DRB
 - Fully differential amplifier
 - Single channel, bridge-tied load (BTL)
 - 2.5-V to 5.5-V operation
 - 1.25-W output power into 8 Ω at 5 V, BTL
 - Internal depop and quick start-up circuitry
 - Internal thermal and short-circuit protection
 - Module gain is set at 2 V/V
- Quick and Easy Configuration With the TI Plug-n-Play Audio Amplifier Evaluation Platform
 - Evaluation module is designed to simply plug into the platform, automatically making all signal, control, and power connections.
 - Platform provides flexible power options.
 - Jumpers on the platform select power and module control options.
 - Switches on the platform route signals.
 - Platform provides quick and easy audio input and output connections.
- Platform Power Options
 - Onboard 9-V battery
 - External 5-V to 15-V (V_{CC}) supply inputs
 - External regulated V_{DD} supply input
 - Socket for onboard 5-V/3.3-V V_{DD} voltage regulator EVM
 - Onboard overvoltage and reverse polarity power protection
- Platform Audio Input and Output Connections
 - Left and right RCA phono jack inputs
 - Miniature stereo phone jack input
 - Left and right RCA phono jack outputs
 - Left and right compression speaker terminal outputs
 - Miniature stereo headphone jack output

1.2 Description

The TPA6205A1DRB audio power amplifier evaluation module is a complete, low-power single-channel audio power amplifier. It consists of the TI TPA6205A1DRB 1.25-W low-voltage audio power amplifier IC in a very small DRB package, along with a small number of other parts mounted on a circuit board that is approximately one and a quarter inches square (see [Figure 1](#)).

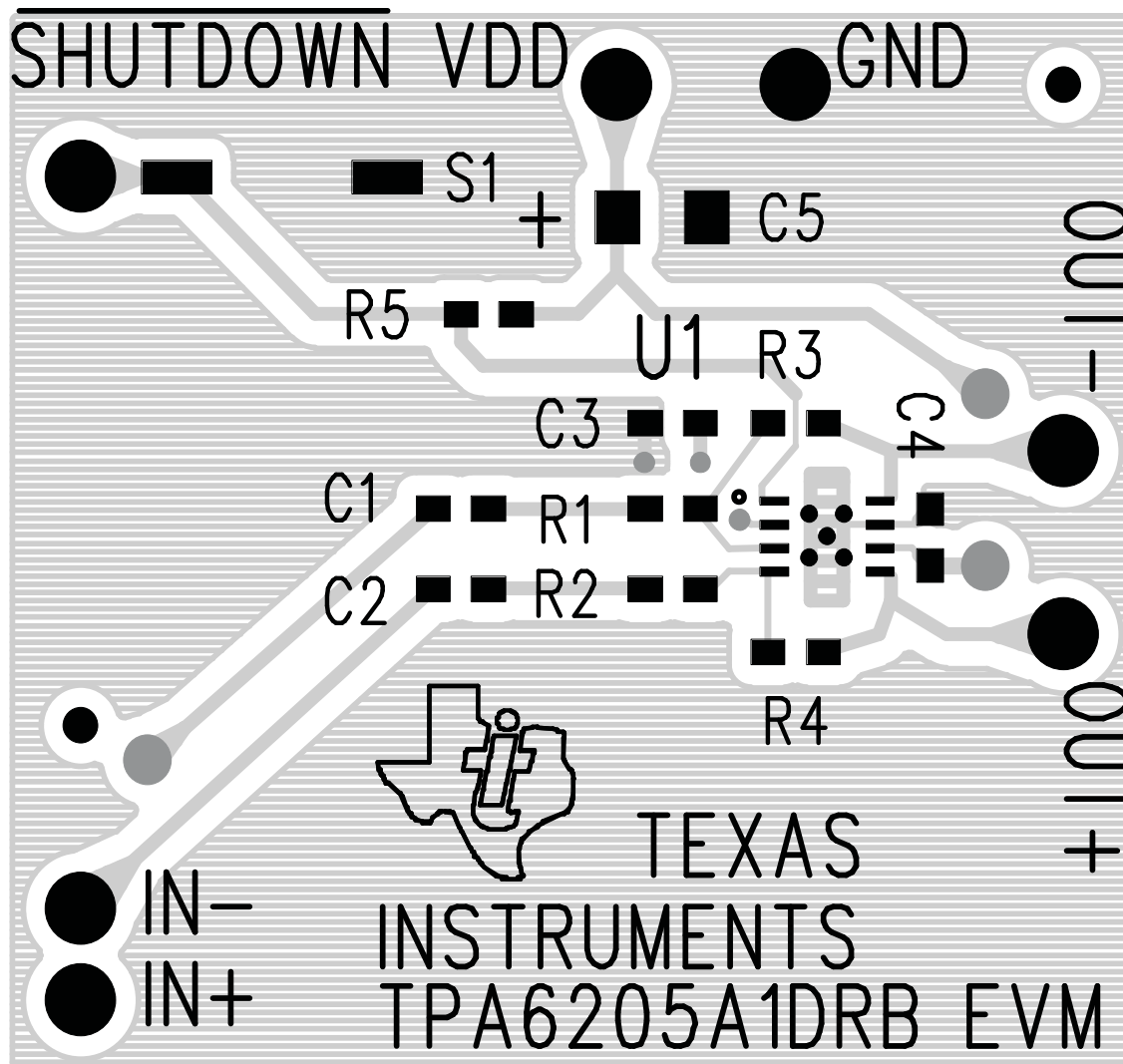

NOTE: Due to the very small size of the DRB IC package, the standard part number TPA6205A1 is replaced with the code AAOI.

Figure 1. The TI TPA6205A1DRB Audio Amplifier Evaluation Module

Single in-line header pins are mounted to the underside of the module circuit board. These pins allow the EVM to be plugged into the TI plug-n-play audio amplifier evaluation platform or to be wired directly into existing circuits and equipment when used stand-alone.

The platform, which has room for a pair of TPA6205A1DRB evaluation modules, is a convenient vehicle for demonstrating TI's audio power amplifier and related evaluation modules. The EVMs simply plug into the platform, which automatically provides power to the modules, interconnects them correctly, and connects them to a versatile array of standard audio input and output jacks and connectors. Easy-to-use configuration controls allow the platform and EVMs to quickly model many possible end-equipment configurations.

There is nothing to build, nothing to solder, and nothing but the speakers included with the platform to hook up.

1.3 TPA6205A1DRB EVM Specifications

		VALUE	UNIT
V_{DD}	Supply voltage range	2.5 to 5.5	V
	Power supply current rating required	450	mA
P_O	Continuous output power, PO: 8Ω BTL, $V_{DD} = 5\text{ V}$	1.25	W
V_I	Audio input voltage	0 V to V_{DD} , max	
Z_L	Minimum load impedance	8	Ω

2 Operation

Follow the steps in this chapter to prepare the TPA6205A1DRB audio amplifier EVM for use. Using the TPA6205A1DRB EVM with the TI plug-n-play audio amplifier evaluation platform is a quick and easy way to connect power, signal and control inputs, and signal outputs to the EVM, using standard connectors. However, the audio amplifier evaluation module can be used stand-alone by making connections directly to the module pins, and it can be wired directly into existing circuits or equipment.

The platform switch and jumper settings shown in [Table 1](#) are typical for the TPA6205A1DRB EVM. They cause the TPA6205A1DRB amplifier IC on the EVM to shut down when a plug is inserted into platform headphone jack J10.

Table 1. Typical TI Plug-N-Play Platform Jumper and Switch Settings for the TPA6205A1DRB EVM

EVM	JP6	JP7	JP8	S2	S3
TPA6205A1DRB	Mute	X ⁽¹⁾	Lo	See ⁽²⁾	X ⁽¹⁾

⁽¹⁾ X = Don't care

⁽²⁾ Set S2 to ON when signal conditioning board is installed in U1; set S2 to OFF when no signal conditioning board is installed.

2.1 Precautions

CAUTION

Power Supply Input Polarity and Maximum Voltage

Always ensure that the polarity and voltage of the external power connected to V_{CC} power input connector J1, J2, and/or V_{DD} power input connector J6 are correct. Overvoltage or reverse-polarity power applied to these terminals can open onboard soldered-in fuses and cause other damage to the platform, installed evaluation modules, and/or the power source.

CAUTION

Inserting or Removing EVM Boards

Do not insert or remove EVM boards with power applied—damage to the EVM board, the platform, or both may result.

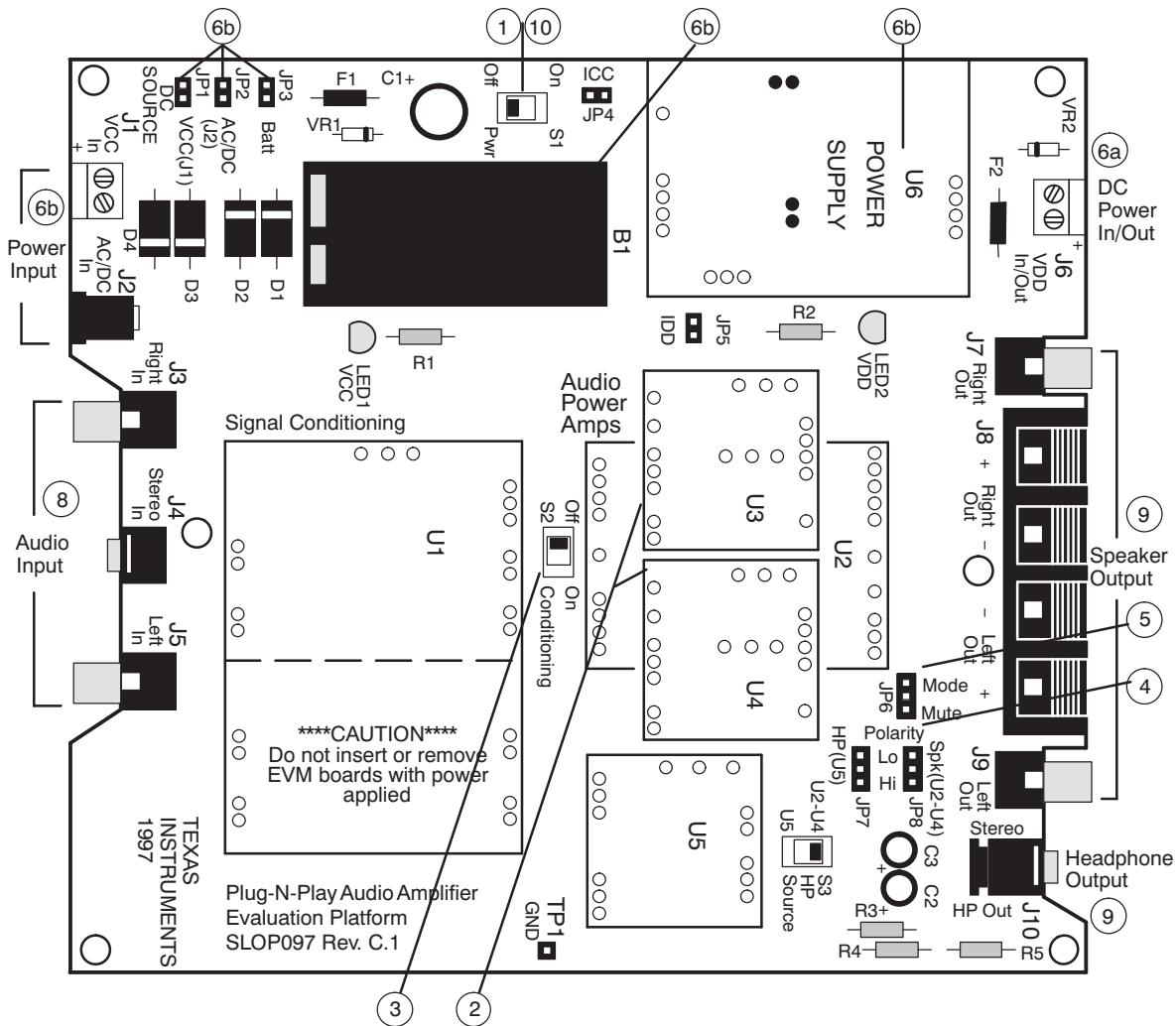

Figure 2. Quick Start Platform Map

2.2 Quick Start List for Platform

Follow these steps when using the TPA6205A1DRB EVM with the TI plug-n-play audio amplifier evaluation platform (see the platform user's guide, [SLOU011](#), for additional details). Numbered callouts for selected steps are shown in [Figure 2](#).

Platform preparations:

1. Ensure that all external power sources are set to off and that the platform power switch S1 is set to off.
2. Install a TPA6205A1DRB module in platform sockets U3 and U4 for stereo operation (or a module in either U3 or U4 for single channel operation), taking care to align the module pins correctly.
3. Use switch S2 to select or bypass the signal conditioning EVM (U1).
4. Set control signal polarity jumper JP8 to Lo.
5. Set jumper JP6 to select the mute control input (which causes the TPA6205A1DRB to shut down if a plug is inserted into platform headphone jack J10).

Table 2. Platform Jumper and Switch Settings for the TPA6205A1DRB EVM

EVM	JP6	JP7	JP8	S2	S3
TPA6205A1DRB	Mute	X ⁽¹⁾	Lo	See ⁽²⁾	X ⁽¹⁾

⁽¹⁾ X = Don't care

⁽²⁾ Set S2 to ON when signal conditioning board is installed in U1; set S2 to OFF when no signal conditioning board is installed.

Selecting and connecting the power supply:

- 6a. Connect an external regulated power supply set to a voltage between 2.5 V and 5.5 V to platform V_{DD} power input connector J6, taking care to observe marked polarity,
OR
- 6b. Install a voltage regulator EVM ([SLVP097](#) or equivalent.) in platform socket U6. Install a 9-V battery in B1 or connect a 7 V–12 V power source to a platform V_{CC} power input J1 or J2 and jumper the appropriate power input (see platform user's guide).

Inputs and Outputs Setup:

7. Ensure that signal source level is set to minimum.
8. Connect the audio source to left and right RCA phono jacks J3 and J5 or to stereo miniature phone jack J4.
9. Connect 8 Ω –32 Ω speakers to left and right RCA jacks J7 and J9 or to stripped wire connector J8.

Power-Up Procedure:

10. Verify correct voltage and input polarity and set the external power supply to on. If V_{CC} and an on-board regulator EVM are used to provide V_{DD} , set platform power switch S1 to on. Platform LED2 lights, indicating the presence of V_{DD} , and the evaluation modules installed on the platform begin operation.
11. Adjust the signal source level as needed.

2.3 Quick Start List for Stand-Alone

Follow these steps to use the TPA6205A1DRB EVM stand-alone or when connecting it into existing circuits or equipment. Connections to the TPA6205A1DRB module header pins can be made via individual sockets, wire-wrapping, or soldering to the pins, either on the top or the bottom of the module circuit board. Numbered callouts for selected steps are shown in [Figure 3](#).

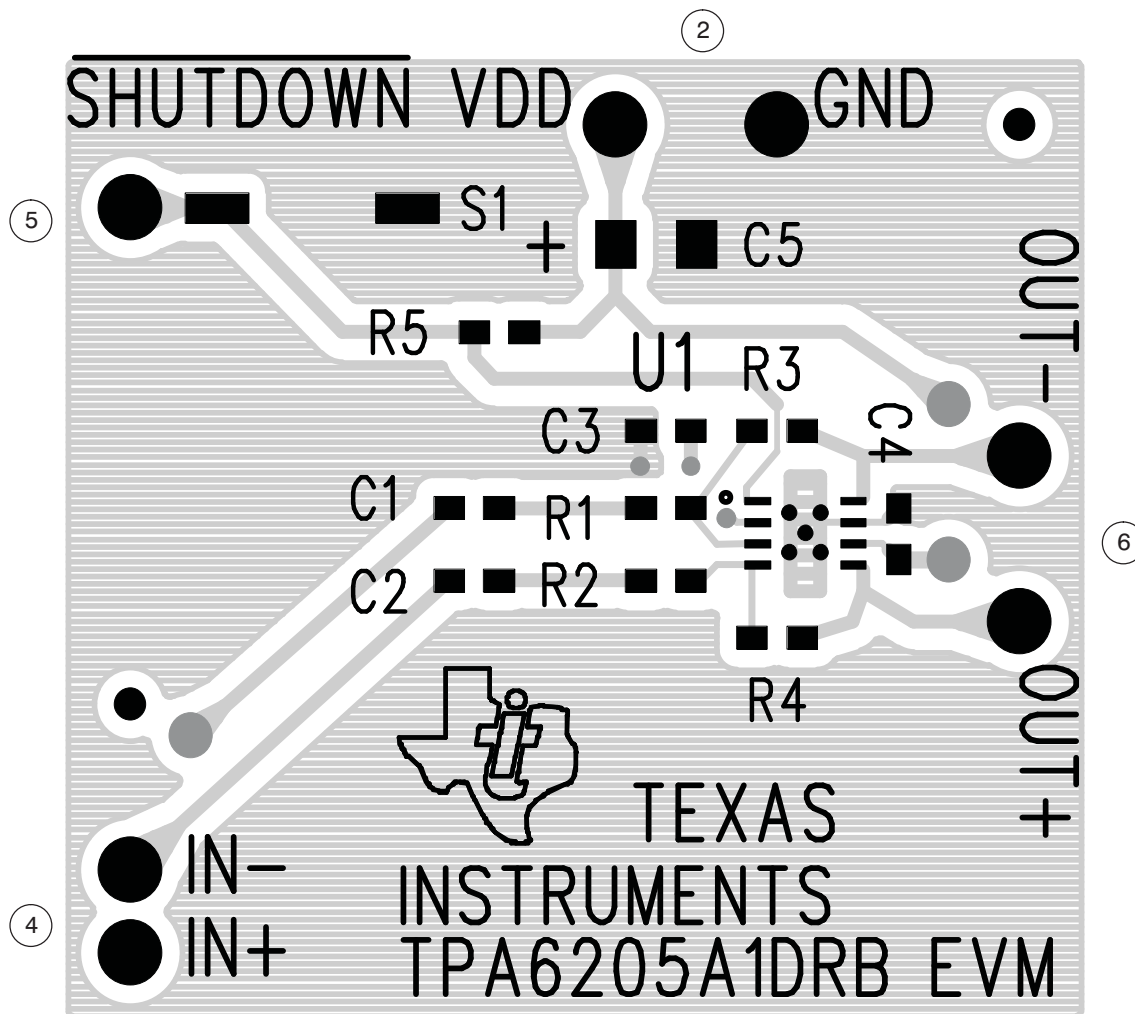

NOTE: Due to the very small size of the DRB IC package, the standard part number TPA6205A1 is replaced with the code AAOI.

Figure 3. Quick Start Module Map

Power Supply Setup

1. Ensure that all external power sources are set to off.
2. Connect an external regulated power supply set to 5 V to the module V_{DD} and GND pins, taking care to observe marked polarity.

Setting the Inputs and Outputs

3. Ensure that the signal source level is set to minimum.
4. Connect the positive lead from the audio source to module IN+ pin, negative lead to the IN- pin.
5. Connect the **SHUTDOWN** pin through a normally open switch to GND.
6. Connect an 8 Ω –32 Ω speaker to the module OUT+ and OUT- pins.

Power-Up Procedure

7. Verify correct voltage, input polarity; set external power supply to on. The EVM begins operation.
8. Adjust the signal source level as needed.

2.4 References

2.4.1 TPA6205A1DRB EVM Connected for Stereo BTL Output

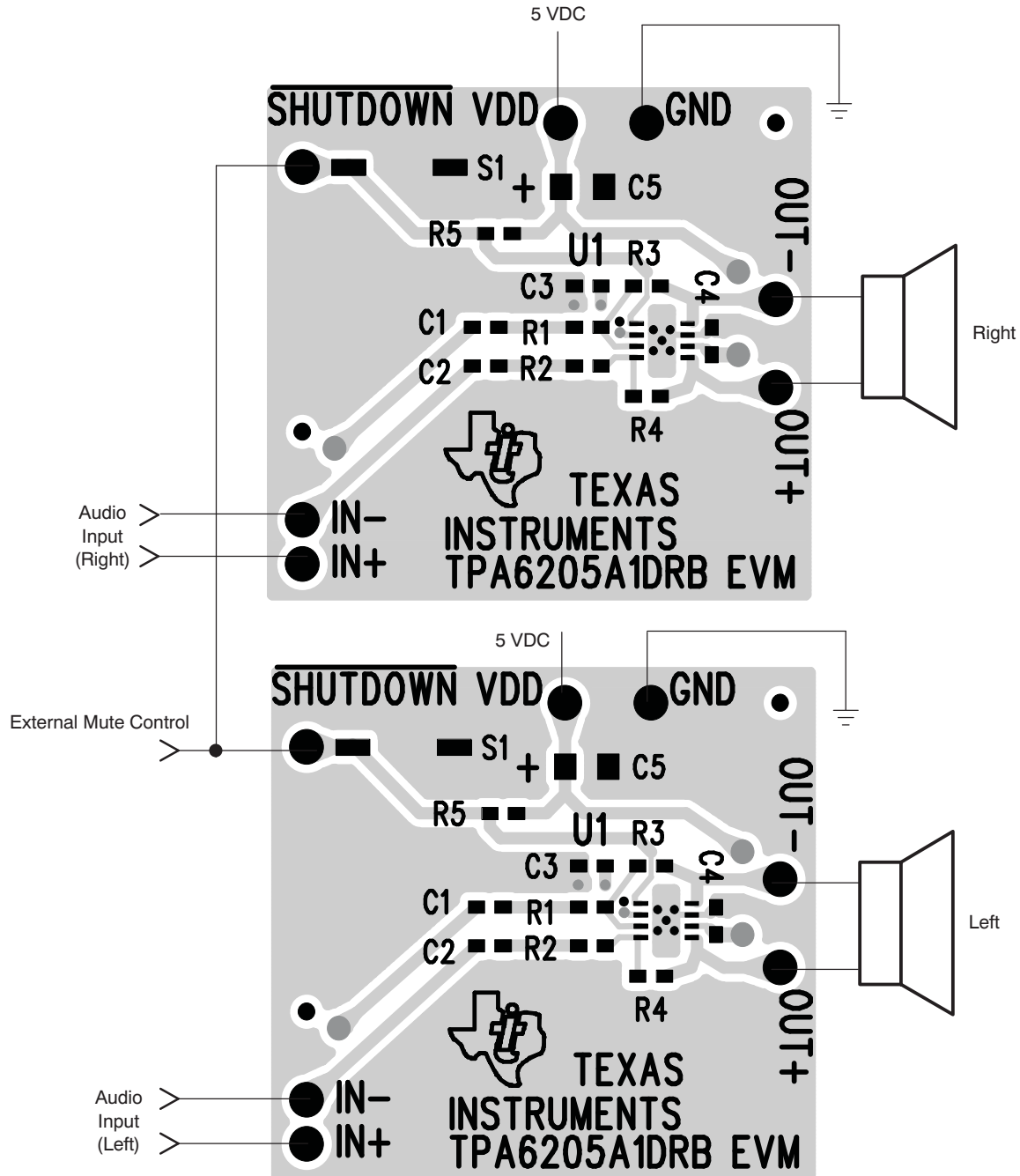

NOTE: Due to the very small size of the DRB IC package, the standard part number TPA6205A1 is replaced with the code AAOI.

Figure 4. TPA6205A1DRB EVM Connected for Stereo BTL Output

2.4.2 TPA6205A1DRB EVM Schematic Diagram

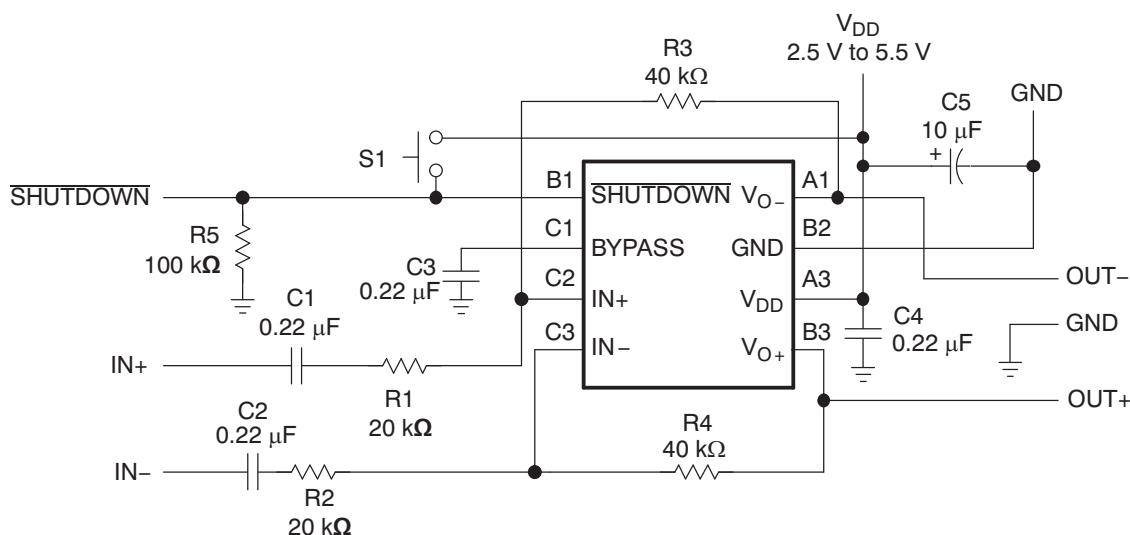

Figure 5. TPA6205A1DRB EVM Schematic Diagram

2.4.3 TPA6205A1DRB Audio Power Amplifier Evaluation Module Parts List

Table 3. TPA6205A1DRB EVM Parts List⁽¹⁾

Reference	Description	Size	Qty	Manufacturer/ Part Number	Digi-Key Number
C5	Capacitor, 10μF, 10V	A	1	Kemet T491A106K010AT	Digi-Key 399-3684-1-ND
C1–C4	Capacitor, 0.22μF, 80%/–20%, nonpolarized	0603	4	AVX 0603ZC224KAT2A	Digi-Key 478-1243-1-ND
R1, R2	Resistor, 20kΩ, 1/16 W, 1%	0603	2	Panasonic ERJ-3EKF2002V	Digi-Key P20.0KHTR-ND
R3, R4	Resistor, 40kΩ, 1/16 W, 1%	0603	2	Panasonic ERJ-3EKF4022V	Digi-Key P40.2KHTR-ND
R5	Resistor, 100kΩ, 1/16 W, 1%	0603	1	Panasonic ERJ-3EKF1003V	Digi-Key P100KHTR-ND
S1	Switch, momentary		1	Panasonic EVQ-PJS04K	Digi-Key P8048SCT-ND
	Terminal post headers		7	Sullins PTC36SABN	Digi-Key S1022-36-ND
U1	IC, TPA6205A1DRB(1), audio amplifier, 1.25W, mono	3 mm × 3mm	1	TI TPA6205A1DRB	
PCB1	PCB, TPA6205A1DRB EVM		1		

⁽¹⁾ All items are SMD except terminal posts.

2.4.4 TPA6205A1DRB EVM PCB Layers

The following illustrations depict the TPA6205A1DRB EVM PCB layers and silkscreen. These drawings are not to scale. Gerber plots can be obtained from www.ti.com.

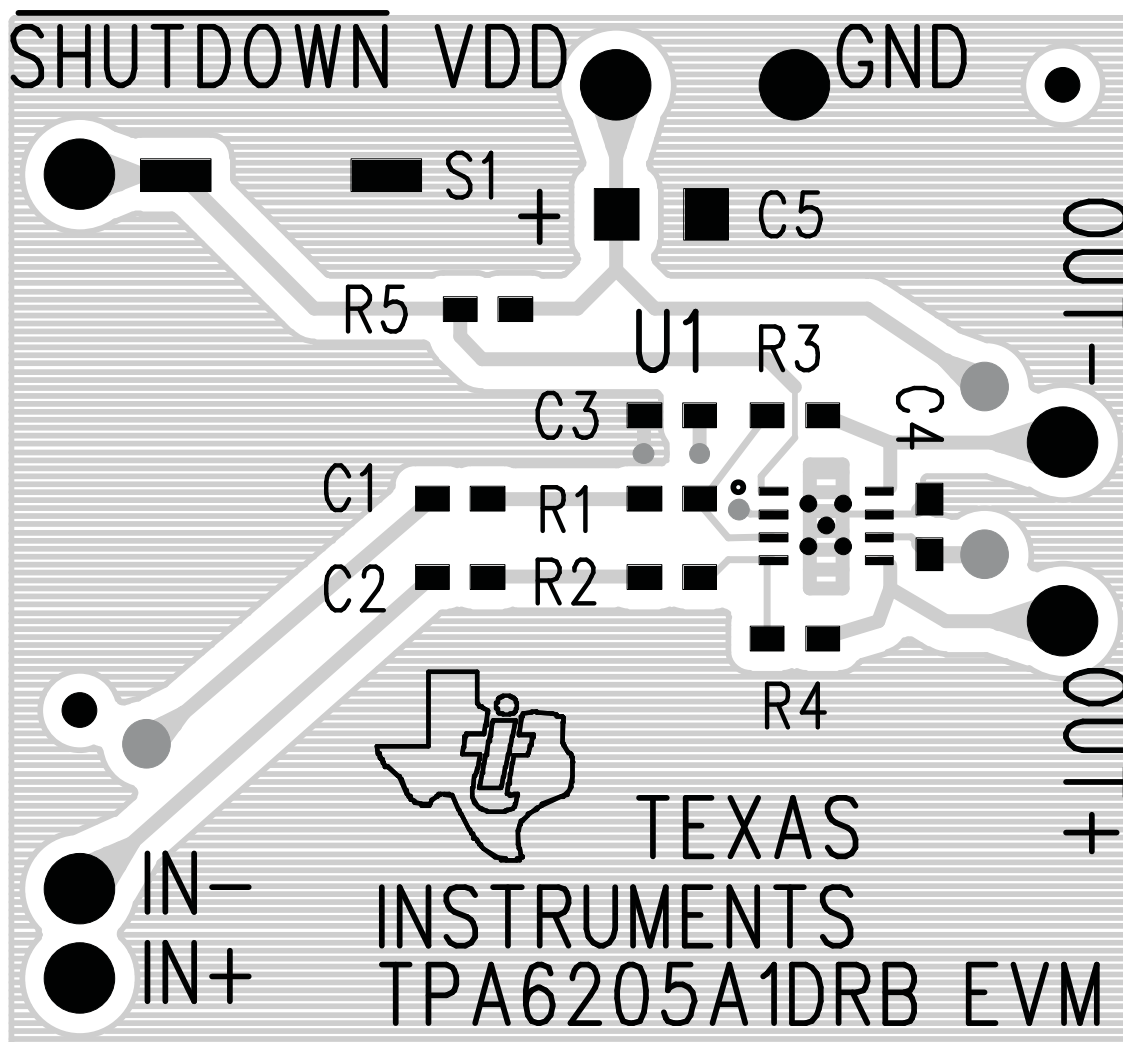

Figure 6. TPA6205A1DRB EVM Top Layer

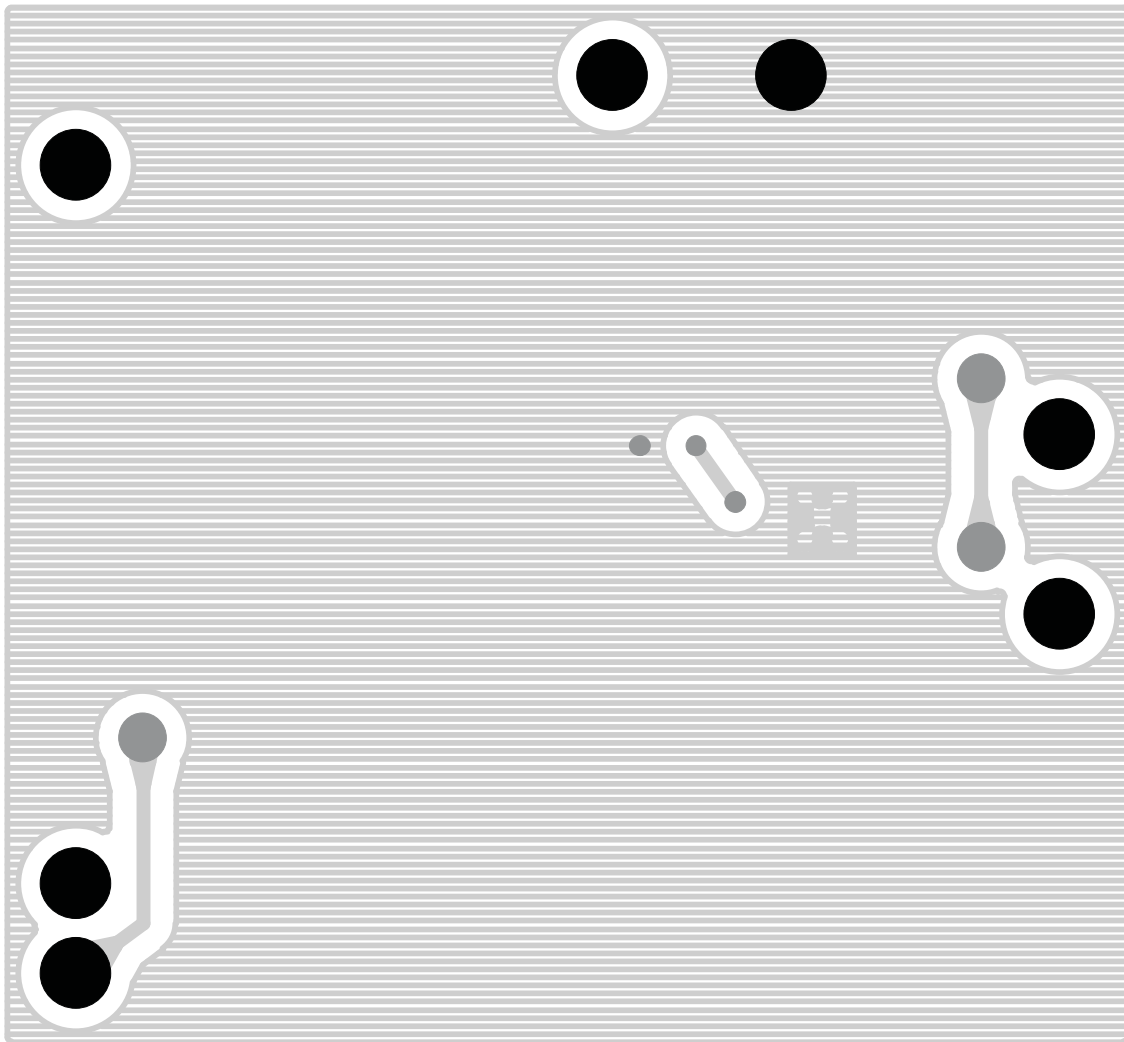

Figure 7. TPA6205A1DRB EVM Bottom Layer

3 Related Documentation From Texas Instruments

- **TI Plug-N-Play Audio Amplifier Evaluation Platform** ([SLOU011](#)) provides detailed information on the evaluation platform and its use with TI audio evaluation modules.
- **TPA6205A1DRB 1.25-W Mono Fully Differential Audio Power Amplifier** ([SLOS490](#)) This is the data sheet for the TPA6205A1DRB audio amplifier integrated circuit.

IMPORTANT NOTICE

Texas Instruments Incorporated and its subsidiaries (TI) reserve the right to make corrections, modifications, enhancements, improvements, and other changes to its products and services at any time and to discontinue any product or service without notice. Customers should obtain the latest relevant information before placing orders and should verify that such information is current and complete. All products are sold subject to TI's terms and conditions of sale supplied at the time of order acknowledgment.

TI warrants performance of its hardware products to the specifications applicable at the time of sale in accordance with TI's standard warranty. Testing and other quality control techniques are used to the extent TI deems necessary to support this warranty. Except where mandated by government requirements, testing of all parameters of each product is not necessarily performed.

TI assumes no liability for applications assistance or customer product design. Customers are responsible for their products and applications using TI components. To minimize the risks associated with customer products and applications, customers should provide adequate design and operating safeguards.

TI does not warrant or represent that any license, either express or implied, is granted under any TI patent right, copyright, mask work right, or other TI intellectual property right relating to any combination, machine, or process in which TI products or services are used. Information published by TI regarding third-party products or services does not constitute a license from TI to use such products or services or a warranty or endorsement thereof. Use of such information may require a license from a third party under the patents or other intellectual property of the third party, or a license from TI under the patents or other intellectual property of TI.

Reproduction of information in TI data books or data sheets is permissible only if reproduction is without alteration and is accompanied by all associated warranties, conditions, limitations, and notices. Reproduction of this information with alteration is an unfair and deceptive business practice. TI is not responsible or liable for such altered documentation.

Resale of TI products or services with statements different from or beyond the parameters stated by TI for that product or service voids all express and any implied warranties for the associated TI product or service and is an unfair and deceptive business practice. TI is not responsible or liable for any such statements.

Following are URLs where you can obtain information on other Texas Instruments products and application solutions:

Products		Applications	
Amplifiers	amplifier.ti.com	Audio	www.ti.com/audio
Data Converters	dataconverter.ti.com	Automotive	www.ti.com/automotive
DSP	dsp.ti.com	Broadband	www.ti.com/broadband
Interface	interface.ti.com	Digital Control	www.ti.com/digitalcontrol
Logic	logic.ti.com	Military	www.ti.com/military
Power Mgmt	power.ti.com	Optical Networking	www.ti.com/opticalnetwork
Microcontrollers	microcontroller.ti.com	Security	www.ti.com/security
		Telephony	www.ti.com/telephony
		Video & Imaging	www.ti.com/video
		Wireless	www.ti.com/wireless

Mailing Address: Texas Instruments
Post Office Box 655303 Dallas, Texas 75265

Copyright © 2006, Texas Instruments Incorporated